

# EcoMo Auto Operation High Speed Hand Dryer

## High Speed Hand Dryer Solutions



ML\_ECOMOROUND\_SIL



ML\_ECOMOROUND\_BLK

### SPECIFICATIONS

<b>Cover/Specify</b>	3.0mm thick molded Antibacterial ABS Plastic Silver: ML_ECOMOROUND_SIL Black: ML_ECOMOROUND_BLK
<b>Motor</b>	350-700W, 12,000 - 18,000 R.P.M., Adjustable Brush Motor
<b>Motor Thermal Protection</b>	Auto resetting thermostat turns unit off, 240V/277V at 95°C
<b>Power Use</b>	220-240 Vac, 50/60 Hz, 6.1-6.7A, 1.34 -1.6Kw
<b>Standby Power</b>	0.3 - 0.4W
<b>LED Colour</b>	Standby: Red, Active: Blue
<b>Sound Level</b>	Min. 72.2dB to 75.4dB Max. at 1m
<b>Drying Time</b>	10-15 seconds
<b>Drip Proof</b>	IP21 or IP24 (optional)
<b>Heater Element</b>	ON/OFF switch available, Power 450-900W depending on air speed
<b>Heater Thermal Protection</b>	Auto resetting thermostat turns off unit at 85°C, Thermal cut-off at 142°C
<b>Warm Air Speed</b>	75-90m/s (adjustable)
<b>Air Output</b>	55°C - Ambient Temp. 25°C
<b>Timer Protection</b>	60 seconds auto shut off
<b>Circuit/ Sensor Range</b>	Circuit Operation - Infrared Automatic, Self-Adjusting Sensor Range Standard 170mm ± 20mm adjustable
<b>Case Security</b>	SS theft resistant hex drive screws (hex key supplied)
<b>Net Weight &amp; Dimensions</b>	9.4kg 322mm W x 624.5mm H x 185mm D
<b>Filter</b>	Super filter assembly consisting of Antibacterial Filter · Carbon Filter · HEPA Filter
<b>Warranty</b>	5 Year Warranty (3 Years Parts & Labour · 2 Years Parts Only)
<b>Notes</b>	* Unit can be hard wired by electrician or used with a cord and plug provided * This unit is deemed disabled complaint when installed with AS1428.1 Guidelines.

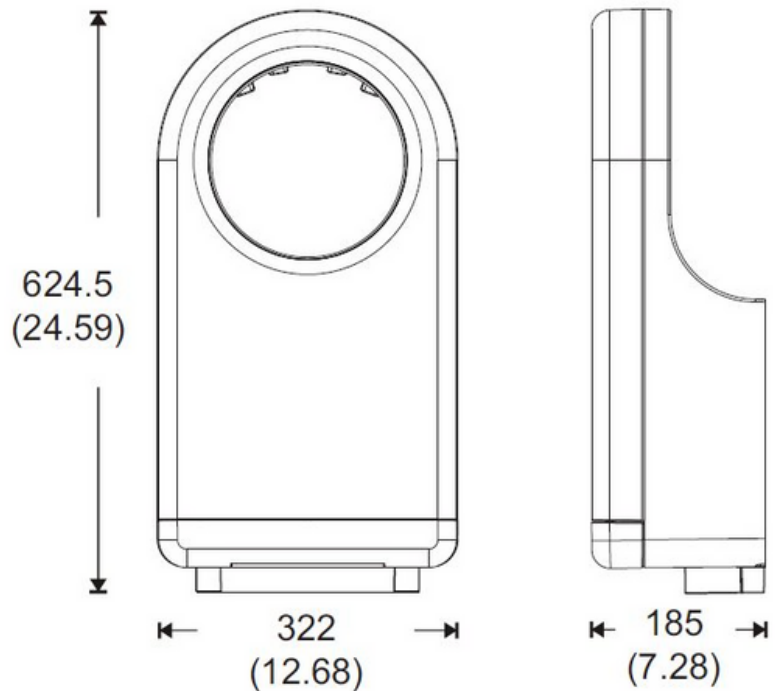

Safety Approvals



Green Certificates

